



# **GSM CONTROLLER**

**User Manual**

*eldes*

**Downee**

## SAFETY INSTRUCTIONS

Please read and follow these safety guidelines to safeguard yourself and others:

- GSM switch-gate controller ESIM120 (later referred to as “the system” or “the device”) contains a built-in radio transceiver operating in GSM 850/900/1800/1900 MHz bands.
- DO NOT use the system where it can cause potential danger and interfere with other devices - such as medical devices.
- DO NOT use the system in hazardous environment.
- DO NOT expose the system to high humidity, chemical environment or mechanical impact.
- DO NOT attempt to repair the system yourself - any repairs must be carried out by fully qualified personnel only.



Disconnect the mains power before installing. Never install or carry out maintenance during stormy weather. The electric socket that powers the system must be easily accessible.



Please use the 10-24V 50Hz ~200mA AC or 10-24V  $\text{---}$  200mA DC power supply unit that meets the EN 60950-1 standard. Any additional device you connect to the system, such as a computer, must also be powered by an EN 60950-1 approved supply. When connecting the power supply to the system, switching the polarity terminal places does not have any affect.



External power supply can be connected to AC mains only inside installation room with automatic 2-pole circuit breaker capable of disconnecting circuit in the event of short circuit or over-current condition. Open circuit breaker must have a gap between connections of more than 3mm (0.12in) and the disconnection current 5A.

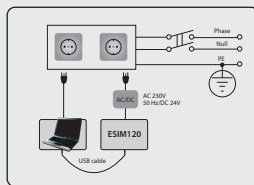

To switch the system off, unplug the external electric power supply from or any other linked device that the system is powered from.



A blown fuse cannot be replaced by the user. The replacement fuse has to be of the kind indicated by the manufacturer (fuse F1 model - MINISMDC050F 0.5A).



If you use a computer for the device configuration, it must be earthed.



The WEEE (Waste Electrical and Electronic Equipment) marking on this product (see left) or its documentation indicates that the product must not be disposed of together with household waste. To prevent possible harm to human health and/or the environment, the product must be disposed on in an approved and environmentally safe recycling process. For further information on how to dispose of this product correctly, contact the system supplier, or the local authority responsible for waste disposal in your area.

# CONTENTS

<b>1. GENERAL INFORMATION</b>	<b>6</b>
<b>2. TECHNICAL SPECIFICATIONS</b>	<b>6</b>
2.1. Electrical and Mechanical Characteristics	6
2.2. Main Unit, LED Indicator and Connector Functionality	7
2.3. Wiring Diagrams	8
<b>3. INSTALLATION</b>	<b>9</b>
<b>4. GENERAL OPERATIONAL DESCRIPTION</b>	<b>10</b>
<b>5. CONFIGURATION METHODS</b>	<b>10</b>
5.1. SMS Text Messages	10
5.2. ELDES Configuration Tool Software	10
5.2.1. Remote Connection	10
5.2.2. Ending the Remote Connection Session	10
<b>6. SYSTEM LANGUAGE</b>	<b>11</b>
<b>7. SMS PASSWORD</b>	<b>11</b>
<b>8. ADMINISTRATOR PHONE NUMBERS</b>	<b>12</b>
<b>9. DATE AND TIME</b>	<b>13</b>
9.1. Automatic Date and Time Synchronization	13
<b>10. USER PHONE NUMBER DATABASE</b>	<b>14</b>
10.1. User Validity and Access Restriction	16
<b>11. OUTPUTS</b>	<b>18</b>
11.1. Output Names	18
11.2. Output Control by Free of Charge Phone Call	18
11.3. Output Control by SMS Text Message	19
11.4. Output Control Confirmation by Call Back	21
11.5. Output Control from any Phone Number	21
11.6. Automatic Output Control	22
<b>12. SCHEDULERS</b>	<b>23</b>
<b>13. EVENT LOG</b>	<b>25</b>
<b>14. INPUTS</b>	<b>26</b>
14.1. Input Names and Alarm Notifications	26
14.2. Disabling and Enabling Inputs	27
<b>15. SYSTEM INFORMATION. INFO SMS</b>	<b>28</b>
15.1. Periodic Info SMS	28
<b>16. SYSTEM NOTIFICATIONS</b>	<b>29</b>
16.1. SMS Text Message Delivery Restrictions	29
16.2. SMSC (Short Message Service Center) Phone Number	29
<b>17. GPRS NETWORK SETTINGS</b>	<b>30</b>
<b>18. INCOMING PHONE NUMBER VERIFICATION SETTINGS</b>	<b>31</b>
<b>19. REMOTE SYSTEM RESTART</b>	<b>31</b>
<b>20. TECHNICAL SUPPORT</b>	<b>32</b>
20.1. Troubleshooting	32
20.2. Restoring Default Parameters	32
20.3. Updating the Firmware via USB Cable	32
<b>21. ELDES CLOUD SERVICES</b>	<b>33</b>
<b>22. RELATED PRODUCTS</b>	<b>34</b>



## Limited Liability

The buyer agrees that the system will reduce the risk of fire, theft, burglary or other danger but that it does not guarantee against the occurrence of such events. "ELDES UAB" will not take any responsibility for the loss of personal effects, property or revenue whilst using the system. The liability of "ELDES UAB" is limited to the value of the system purchased. "ELDES UAB" is not affiliated with any mobile/wireless/cellular provider and is therefore not responsible for the quality of such services.

## Manufacturer Warranty

The system carries a 24-month manufacturer warranty from "ELDES UAB". The warranty begins the day the system is purchased by the user and the receipt must be retained as proof of purchase date. The warranty remains valid only if the system is used as intended, following all guidelines outlined in this manual and in accordance with the operating conditions specified. The warranty is void if the system has been exposed to mechanical impact, chemicals, high humidity, fluids, corrosive and hazardous environments or force majeure factors.

*Dear Customer,*

*Thank you for choosing to purchase the GSM switch-gate controller ESIM120. Your thoughtful decision will ensure reliable solution for many years as all ELDES products are manufactured to meet the highest standards.*

*We are confident that you will be completely satisfied with your product. However, in the unlikely event that you do experience a problem, please contact the dealer from whom you made your purchase.*

UAB ELDES  
www.eldes.it

## Contents of Pack

Item	Quantity
1. ESIM120.....	1
2. User manual.....	1
3. GSM/GPRS antenna.....	1

### Not included:

- SIM card - we recommend you get a contract SIM, not Pay As You Go.
- mini-USB cable - can be obtained from your local distributor.

Copyright © "ELDES UAB", 2015. All rights reserved.

It is strictly forbidden to copy and distribute information in this document or pass to a third party without an advanced written authorization from "ELDES UAB". "ELDES UAB" reserves the right to update or modify this document and/or related products without a warning. Hereby, "ELDES UAB" declares that the GSM switch-gate controller ESIM120 is in compliance with the essential requirements and other relevant provisions of Directive 1999/5/EC. The declaration of conformity may be consulted at [www.eldes.it](http://www.eldes.it).

**CE 1383**

# 1. GENERAL INFORMATION

ESIM120 is a micro-controller based device intended to provide access control for gate automatics, road barriers or to remotely turn ON/OFF any electrical appliance via the GSM network.

## Examples of using the system:

- Access control.
- Parking lot control of residential houses or offices.
- Gate control of private houses.
- Any electrical appliance control: lighting, watering, heating etc.
- Remote reboot of the “frozen” systems, such as computer network or a server.

## Main features

- Manual output control by free of charge phone call.
- Automatic output control in accordance with the scheduled time.
- Configurable output pulse duration.
- Automatic date and time synchronization.
- Up to 5 administrators for system configuration by SMS text messages, acceptance of input alarm SMS text messages, output control by SMS text message and free of charge phone call.
- User database capacity - up to 2000 users for output control by free of charge phone call.
- User phone number validity limitation in accordance with a set deadline (date/time) or number of rings to the system.
- Output control restriction for users in accordance with the specified weekdays and time.
- Event log of 1000 events containing date and time as well as administrator/user phone number and user name who controlled the output.
- 3 inputs with customizable alarm texts for notification on gate state or in case it gets jammed.
- Periodic self-test notification by SMS text message to administrator phone number.

# 2. TECHNICAL SPECIFICATIONS

## 2.1. Electrical and Mechanical Characteristics

Supply voltage.....	10-24V 50Hz ~ 200mA max / 10-24V $\overline{\text{---}}$ 200mA max
Current used in idle state.....	up to 50mA
GSM modem frequency.....	850/900/1800/1900 MHz
Number of outputs.....	2
Output type.....	Relay; NO (normally-open) or NC (normally-closed) - configurable
Maximum commuting output values.....	24V 50Hz ~ 0,5A / 24V $\overline{\text{---}}$ 1A
Number of low-level (negative) inputs.....	2
Number of high-level (positive) inputs.....	1
Low-level (negative) input value range.....	0... 16V $\overline{\text{---}}$ -0.8... -0.4mA
High-level (positive) input value range.....	5... 50V $\overline{\text{---}}$ 0.17 .... 1.7mA
Low-level (negative) and high-level (positive) input connection type.....	NO (normally-open)
Dimensions.....	87x107x29mm (3.43x4.21x1.14in)
Operating temperature range.....	-20...+55 °C (-30...+55 °C with limitations) (-4...+131°F (-22... +131°F))
Humidity.....	0-90% RH @ 0... +40°C (0-90% RH @ +32... +104°F) (non-condensing)

## 2.2. Main Unit, LED Indicator and Connector Functionality

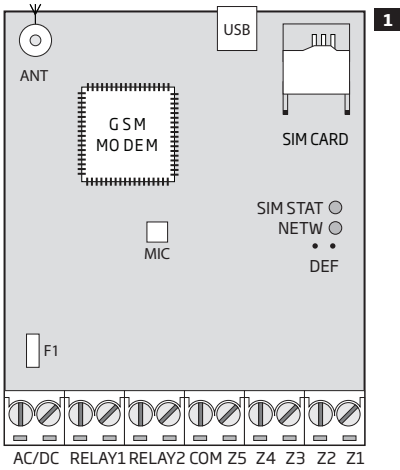

### Main Unit Functionality

ANT	GSM/GPRS antenna SMA type connector
USB	Mini USB port
SIM CARD	SIM card slot / holder
GSM MODEM	GSM network 850/900/1800/1900 MHz modem
MIC	N/A
SIM STAT	Red light-emitting diode indicating SIM card status
NETW	Green light-emitting diode indicating GSM signal strength
DEF	Pins for restoring default settings
F1	0.5A fuse

### Connector Functionality

AC/DC	Power supply terminals
RELAY1	Output C1 terminal
RELAY2	Output C2 terminal
COM	Common terminal
Z5	N/A
Z4	N/A
Z3	Low-level (negative) input terminal
Z2	High-level (positive) input terminal
Z1	Low-level (negative) input terminal

## LED Indicator Functionality

SIM STAT indication	SIM card status
OFF	No mains power / micro-controller fault
Steady ON	SIM card is attempting to connect to the GSM network / SIM card is not present / PIN code enabled
Flashing	GSM connection failed

NETW indication	GSM signal strength
OFF	No GSM signal
Flashing every 1 sec.	Poor
Flashing several times per sec.	Medium
Steady ON	Excellent

## 2.3. Wiring Diagrams

### General wiring

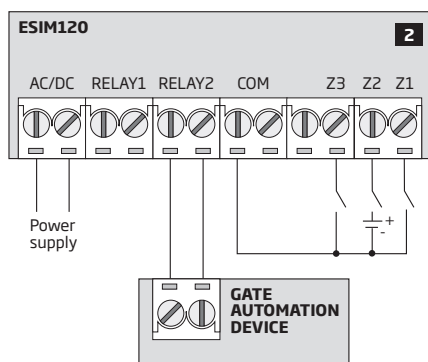

### Example of ESIM120 system wiring to gate automation device

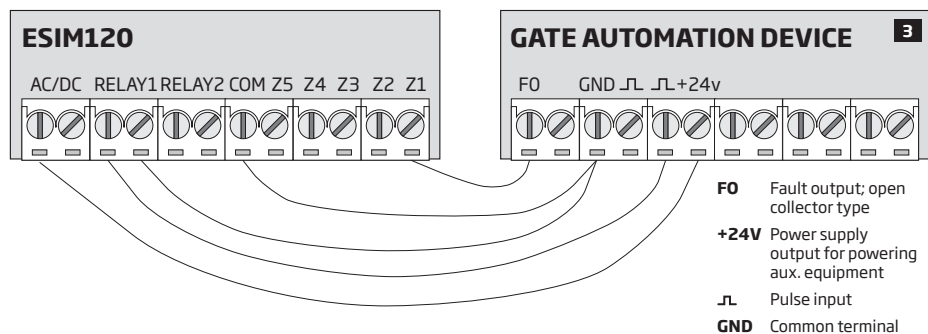

### 3. INSTALLATION

- The system should be installed indoors, in stationary environment ONLY.
- For the connection of input/output terminals, use 0.50 mm<sup>2</sup> (0.02in<sup>2</sup>) thread unshielded cable of up to 100m (328.08ft) length.

1. Wire up the system in accordance with the wiring diagrams (see **2.3 Wiring Diagrams** for more details).
2. Connect the GSM/GPRS antenna. Based on the type of the GSM/GPRS antenna supplied with ESIM120 unit, follow the recommendations for the antenna installation:

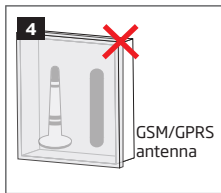

Never install in the following locations:

- inside the metal cabinet
- closer than 20cm (7.87in) from the metal surface and/ or power lines

3. Disable the PIN code request of the SIM card by inserting it into a mobile phone and following the proper menu steps.
4. Once the PIN code is disabled, insert the SIM card into the SIM card slot / holder of ESIM120 system.

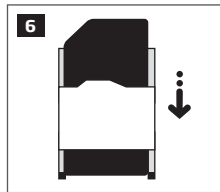
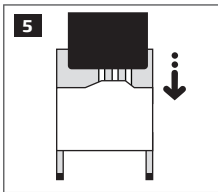

5. Power up the system and wait until indicator SIM STAT lights up indicating SIM card status.
6. Once the indicator SIM STAT lights OFF, the illuminated indicator NETW lights up indicating that the system has successfully connected to the GSM network. To find the strongest GSM signal, position the GSM/GPRS antenna and follow the indications provided by NETW indicator (see **2.2. Main Unit, LED Indicator and Connector Functionality** for more details).
7. Change the system language if necessary (see **6. SYSTEM LANGUAGE** for more details).
8. Change the default SMS password (see **7. SMS PASSWORD** for more details).
9. Set the phone number for Admin 1 (see **8. ADMINISTRATOR PHONE NUMBERS** for more details).
10. Set system date and time (see **9. DATE AND TIME** for more details).
11. Once the system is fully configured, it is ready for use. However, if you fail to receive a reply by SMS text message from the system, please check the SMSC (Short Message Service Center) phone number. For more details regarding the SMS center phone number, please refer to **16.2. SMSC (Short Message Service Center) Phone Number**.

**ATTENTION:** The system is NOT compatible with pure 3G SIM cards. Only 2G/GSM SIM cards and 3G SIM cards with 2G/GSM profile enabled are supported. For more details, please contact your GSM operator.

**ATTENTION:** We also recommend you to disable **call forwarding, voice mail/text message reports on missed/busy calls** and similar services that might cause incorrect system operation. Please contact your GSM operator for more details on these services and how to disable them.

**NOTE:** For maximum system reliability we recommend you do NOT use a Pay As You Go SIM card. Otherwise, in the event of insufficient credit balance on the SIM card, the system would fail to make a phone call or send SMS text messages.

**NOTE:** We advise you to choose the same GSM SIM provider for your system as for your mobile phone. This will ensure the fastest, most reliable SMS text message delivery service and phone call connection.

**NOTE:** Even though the installation process of ESIM120 is not too complicated, we still recommend to perform it by a person with basic knowledge in electrical engineering and electronics to avoid any system damage.

## 4. GENERAL OPERATIONAL DESCRIPTION

When a phone call is made to the phone number of the SIM card inserted in ESIM120, the system will verify if the caller's phone number exists in the memory. If the caller is one of the 5 administrators or the phone number belongs to one of the 2000 database users, the system will reject the phone call, thus making the phone call free of charge, and open the gate. By ringing to ESIM120 again, it will close the gate. If the phone number is not recognized, the system will reject the phone call and ignore it. The GSM switch-gate controller can also control your gate automatically in accordance with the scheduled time or by sending an SMS text message from the administrator's phone number. By connecting a sensor to one of the 3 inputs, the administrators can receive SMS text messages regarding the gates that failed to close during the set time period.



## 5. CONFIGURATION METHODS

### 5.1. SMS Text Messages



In this document the underscore character “\_” represents one space character. Every underscore character must be replaced with a single space character. There must be no spaces or other unnecessary characters at the beginning and at the end of the SMS text message.



In order to configure and control the system by SMS text message, send the text command to the ESIM120 system phone number from one of the listed administrator phone numbers. The structure of SMS text message consists of 4-digit SMS password (the default SMS password is 0000 - four zeros), the parameter and value. For some parameters the value does not apply e.g. STATUS. The variables are indicated in lower-case letters, while a valid parameter value range is indicated in brackets.

### 5.2. ELDES Configuration Tool Software



Software *ELDES Configuration Tool* is intended for ESIM120 GSM switch-gate controller configuration locally via USB port or remotely via GPRS network connection. This software simplifies system configuration process by allowing to use a personal computer in the process. Before starting to use *ELDES Configuration Tool* software, please read the user guide provided in the software's HELP section.

*ELDES Configuration Tool* is freeware and can be downloaded from at: [www.eldes.it](http://www.eldes.it)

**NOTE:** *ELDES Configuration Tool* software is secured with SMS password. The default SMS password is **0000** (see **7. SMS PASSWORD**).

#### 5.2.1. Remote Connection

**ATTENTION:** When ELDES Cloud Services feature is enabled (see **21. ELDES CLOUD SERVICES**), remote connection via *ELDES Configuration Tool* software becomes inaccessible. In such case you may use the remote configuration feature by accessing your ELDES Cloud Services account via web-browser.

*ELDES Configuration Tool* software provides remote system configuration ability via Internet using one of the following methods:

- ELDES proxy server (recommended). The connection can be established on the system via GPRS network.
- Running TCP/IP server on *ELDES Configuration Tool* (advanced). The connection can be established on the system via GPRS network.

In order to start using the remote configuration feature, please run the step-by-step wizard and follow the steps provided in the start page of *ELDES Configuration Tool* software. Please, note that it will be necessary to send an SMS text message to the system's phone number in order to initiate the remote connection. By following the steps you will be instructed on what text must be sent to the system's phone number in such case.

#### 5.2.2. Ending the Remote Connection Session

After the system configuration is complete, use one of the following methods to end the configuration process:

- Click **Disconnect** or **Stop** button and close *ELDES Configuration Tool* software;
- The session will automatically expire in 20 minutes. Before the last 5 minutes, the software will offer the user to extend the session for another 20 minutes.
- Alternatively, the connection with the server can be terminated at any time by sending an SMS text message.

Terminate the connection

**SMS text message content:**

`ssss_ENDCONFIG`

**Value:** ssss - 4-digit SMS password.

**Example:** `1111_ENDCONFIG`

Once the session is expired or terminated, the system will reply with an SMS text message confirming the end of the session.

## 6. SYSTEM LANGUAGE

The system comes equipped with a multiple languages for communication with the administrator by SMS text messages. The default system language depends on the firmware, which is based on the customer's location.

### List of currently available system languages:

- English
- Estonian
- German
- Lithuanian
- French
- Slovak

#### Set system language

SMS

#### SMS text message content:

LN

**Value:** LN - language index; range - [EN - English, EE - Estonian, DE - German, LT - Lithuanian, FR - French, SK - Slovak].

**Example:** LT

Config  
Tool

This operation may be carried out from the PC using the *ELDES Configuration Tool* software.

**NOTE:** To change the language once the system has already been configured, you need to reset the device to the default configuration. For more details on how to do this, please refer to **20.2. Restoring Default Parameters**.

## 7. SMS PASSWORD

For security reasons, the system uses the following type of password:

- **SMS password** - 4-digit password used for system configuration and control from administrator phone number by SMS text messages and logging in to *ELDES Configuration Tool* software. By default, SMS password is **0000**, which **MUST** be changed!

#### Set SMS password

SMS

#### SMS text message content:

wwwwww\_PSW\_ssss

**Value:** wwwwww - 4-digit default SMS password; ssss - 4-digit new SMS password; range - [0001...9999].

**Example:** 0000\_PSW\_1111

Config  
Tool

This operation may be carried out from the PC using the *ELDES Configuration Tool* software.

**NOTE:** The system rejects the SMS text messages containing wrong SMS password even from a listed administrator phone number.

## 8. ADMINISTRATOR PHONE NUMBERS

The system supports up to 5 administrator phone numbers identified as Admin 1 through 5. When the phone number is set, the administrator will be able to configure and control the system by SMS text messages as well as by free of charge phone call and receive the input alarm SMS text messages from the system (see **14.1. Input Names and Alarm Notification**). The system allows to assign output C1, output C2 or both outputs (simultaneous control) to a certain administrator.

By default, the system accepts incoming calls and SMS text messages from any phone number. Once the administrator phone number is listed, the system will ignore any incoming calls and SMS text messages from a non-listed phone number as well as it will reject the SMS text messages containing wrong SMS password even from a listed administrator phone number. For more details on how to enable output control from a non-listed phone number, please refer to **11.5. Output Control from any Phone Number**.

To set Admin 1 phone number is mandatory, while the other 4 are optional. The supported phone number format is the following:

- **International (w/o plus)** - The phone numbers must be entered starting with an international country code in the following format: [international code][area code][local number], example for UK: 44170911XXXX1.

### Set administrator phone number

SMS

#### SMS text message content:

`ssss_NRas:ttteeellnnumm`

**Value:** ssss - 4-digit SMS password; as - administrator phone number slot, range - [1... 5]; ttteeellnnumm - up to 15 digits administrator phone number.

**Example:** 1111\_NR1:44170911XXXX1

Config Tool

This operation may be carried out from the PC using the *ELDES Configuration Tool* software.

### View administrator phone numbers

SMS

#### SMS text message content:

`ssss_HELPNR`

**Value:** ssss - 4-digit SMS password.

**Example:** 1111\_HELPNR

Config Tool

This operation may be carried out from the PC using the *ELDES Configuration Tool* software.

### Assign output (-s) to individual administrator

Config Tool

This operation may be carried out from the PC using the *ELDES Configuration Tool* software.

### Delete administrator phone number

SMS

#### SMS text message content:

`ssss_NRas:DEL`

**Value:** ssss - 4-digit SMS password; as - administrator phone number slot, range - [2... 5].

**Example:** 1111\_NR2:DEL

Config Tool

This operation may be carried out from the PC using the *ELDES Configuration Tool* software.

**ATTENTION:** NEVER set a phone number of the device's SIM card as an administrator phone number!

**ATTENTION:** Once Admin 1 phone number is set, the system will restrict only to modify it.

**ATTENTION:** Multiple administrator phone numbers can be set by a single SMS text message, **Example:** 1111\_NR1:44170911XXXX1\_NR5:44170911XXXX2\_NR2:44170911XXXX3\_NR3:44170911XXXX4

**NOTE:** Multiple administrator phone numbers can be deleted by a single SMS text message, **Example:** 1111\_NR2:DEL\_NR4:DEL\_NR3:DEL

**NOTE:** The administrator can control any output by SMS text message regardless of the output assigned to the administrator phone number (see **11.3. Output Control by SMS Text Message**).

**NOTE:** By default, the system is restricted to send out up to 25 SMS text messages daily and up to 400 SMS text messages monthly. For more details on SMS text message delivery restriction management, please refer to **16.1. SMS Text Message Delivery Restrictions**

For more details on output control, please refer to **11. OUTPUTS**.

## 9. DATE AND TIME

The system comes equipped with internal real-time clock (RTC) that keeps track of the current date and time. Once the system is up and running, the user must set the correct date and time, otherwise the system will not operate properly. By default, after shutting down and starting up the system, the date and time must be set again. In order to avoid manual date and time set up, please use the automatic date and time synchronization feature (see **9.1. Automatic Date and Time Synchronization**).

### Set date and time

#### SMS

##### SMS text message content:

`ssss_yyyy.mm.dd_hr:mn`

**Value:** *ssss* - 4-digit SMS password; *yyyy* - year; *mm* - month, range - [01... 12]; *dd* - day, range - [01... 31]; *hr* - hours, range - [00... 23]; *mn* - minutes, range - [00... 59].

**Example:** `1111_2013.03.16_14:33`

#### Config Tool

This operation may be carried out from the PC using the *ELDES Configuration Tool* software.

### 9.1. Automatic Date and Time Synchronization

This feature enables the system to set the date and time automatically without the user being involved in this process. The system supports the following methods of automatic date and time synchronization that are used automatically on system start-up and periodically (by default - every 30 days):

- **Via GSM network** - Once enabled, the system automatically sends a date/time request to the GSM operator. This method is the most accurate synchronization method. Some GSM operators might not support it.
- **By SMS text message** - Once enabled, the system automatically sends the SMS text message to its own phone number and retrieves the date and time from the SMS text message reply, as the included date and time is set by the SMSC (SMS center). This method is not as accurate as the synchronization via GSM network, but always effective.

By default, synchronization via GSM network is disabled. To enable/disable automatic date and time synchronization via GSM network, please refer to the following configuration methods.

### Enable/disable synchronization via GSM network

#### Config Tool

This operation may be carried out from the PC using the *ELDES Configuration Tool* software.

By default, synchronization by SMS text message is disabled. To enable/disable automatic date and time synchronization by SMS text message, please enter/remove device phone number using one of the following configuration methods.

### Enter/remove device phone number for synchronization by SMS text message

#### Config Tool

This operation may be carried out from the PC using the *ELDES Configuration Tool* software.

By default, the date and time synchronization period is 30 days. To set a different period, please refer to the following configuration methods.

### Set synchronization period

#### Config Tool

This operation may be carried out from the PC using the *ELDES Configuration Tool* software.

**NOTE:** When setting up automatic date and time synchronization feature remotely, you may wish to restart the system when done. For more details, please refer to **19. REMOTE SYSTEM RESTART**.

**NOTE:** 0 value disables periodic date and time synchronization.

**NOTE:** When both synchronization methods are enabled, the system will always attempt to synchronize date and time via GSM network every time the system shuts down and starts up again and in accordance with the set period value. In the event of first method's failure, the system will attempt to use the SMS text message method as a backup.

## 10. USER PHONE NUMBER DATABASE

The system comes equipped with a user database of 2000 user capacity. When the phone number is set, the user will be able to control the output (-s) by free of charge phone call. The user database allows to assign output C1, output C2 or both outputs (simultaneous control) to a certain user. The supported phone number format is the following:

- **International (w/o plus)** - The phone numbers must be entered starting with an international country code in the following format: [international code][area code][local number], example for UK: 44170911XXXX1.

User database supports user validity and access restriction features. For more details, please refer to **10.1. User Validity and Access Restriction**.

Optionally, a user name can be set that typically specifies the owner's name of a certain phone number, for example: *John*.

The phone number and user name (if any) are used when searching for a certain user in the database as well as they are automatically added in the event log after the successful output control event (see **13. EVENT LOG**).

Add user phone number (and user name)

SMS

**SMS text message content:**

`ssss_N:ttteeellnnumm` or `ssss_N:ttteeellnnumm:user-name`

**Value:** `ssss` - 4-digit SMS password; `ttteeellnnumm` - up to 15 digits user phone number; `user-name` - up to 16 characters user name.

**Example:** `1111_N:44170911XXXX1:John`

Config Tool

This operation may be carried out from the PC using the *ELDES Configuration Tool* software.

View user phone numbers

SMS

**SMS text message content:**

`ssss_GETALLNUMBERS`

**Value:** `ssss` - 4-digit SMS password.

**Example:** `1111_GETALLNUMBERS`

Config Tool

This operation may be carried out from the PC using the *ELDES Configuration Tool* software.

Search for user by phone number or name

SMS

**SMS text message content:**

`ssss_T:ttteeellnnumm` or `ssss_T:user-name`

**Value:** `ssss` - 4-digit SMS password; `ttteeellnnumm` - up to 15 digits user phone number; `user-name` - up to 16 characters user name.

**Example:** `1111_T:John`

Config Tool

This operation may be carried out from the PC using the *ELDES Configuration Tool* software.

Assign output (-s) to individual user

SMS

**SMS text message content:**

`ssss_OUTPUT_ttteeellnnumm_o` or `ssss_OUTPUT_user-name_o`

**Value:** `ssss` - 4-digit SMS password; `ttteeellnnumm` - up to 15 digits user phone number; `o` - output number; range - [1 - output C1; 2 - output C2; 3 - both outputs]; `user-name` - up to 16 characters user name.

**Example:** `1111_OUTPUT_44170911XXXX1_2`

Config Tool

This operation may be carried out from the PC using the *ELDES Configuration Tool* software.

### Delete individual user

**SMS**

**SMS text message content:**

`ssss_D:ttteeellnnuumm` or `ssss_D:user-name`

**Value:** `ssss` - 4-digit SMS password; `ttteeellnnuumm` - up to 15 digits user phone number; `user-name` - up to 16 characters user name.

**Example:** `1111_D:John`

**Config Tool**

This operation may be carried out from the PC using the *ELDES Configuration Tool* software.

### Delete all users

**SMS**

**SMS text message content:**

`ssss_D:ALL`

**Value:** `ssss` - 4-digit SMS password.

**Example:** `1111_D:ALL`

**Config Tool**

This operation may be carried out from the PC using the *ELDES Configuration Tool* software.

The user database can be exported/imported to/from a .csv file for backup purposes or for a convenient user database management. To export/import an existing user database, please refer to the following configuration method.

### Export/import existing user database from/to file

**Config Tool**

This operation may be carried out from the PC using the *ELDES Configuration Tool* software.

By default, the user database is enabled and output control by all database users is permitted. To deny output control instead of deleting all users from the database, please disable the user database using one of the following configuration methods.

### Disable user database

**SMS**

**SMS text message content:**

`ssss_DBM_OFF`

**Value:** `ssss` - 4-digit SMS password.

**Example:** `1111_DBM_OFF`

**Config Tool**

This operation may be carried out from the PC using the *ELDES Configuration Tool* software.

To enable user database, please refer to the following configuration methods.

### Enable user database

**SMS**

**SMS text message content:**

`ssss_DBM_ON`

**Value:** `ssss` - 4-digit SMS password.

**Example:** `1111_DBM_ON`

**Config Tool**

This operation may be carried out from the PC using the *ELDES Configuration Tool* software.

**ATTENTION:** Space and colon characters are NOT allowed in the user names.

**NOTE:** Multiple users can be added by a single SMS text message, e.g. `1111_N:44170911XXXX1:John_44170911XXXX2:_44170911XXXX3:Tom`

**NOTE:** Multiple users can be deleted by a single SMS text message, e.g. `1111_D:John_44170911XXXX3_Mark`

For more details on output control, please refer to **11. OUTPUTS**.

## 10.1. User Validity and Access Restriction

The system allows to restrict access in accordance with the scheduler assigned to a certain user. When one or more schedulers are assigned, the user will be able to control the output only on the specified weekdays and time set up in the scheduler. The system allows to assign up to 8 different schedulers. For more details on how to set up the schedulers, please refer to **12. SCHEDULERS**.

In addition, the system allows to limit the user validity by the following methods:

- **Deadline (valid until)** - When a specified date and time hits, the user will be automatically deleted from the database.
- **Ring counter** - When a specified number of phone calls to the system expires, the user will be automatically deleted from the database.

### Assign scheduler to individual user

**SMS**

**SMS text message content:**

`ssss_NSCHED_ttteeellnnumm_c:ON` or `ssss_NSCHED_user-name_c:ON`

**Value:** `ssss` - 4-digit SMS password; `ttteeellnnumm` - up to 15 digits user phone number; `c` - scheduler number; range - [1... 8]; `user-name` - up to 16 characters user name.

**Example:** `1111_NSCHED_John_5:ON`

**Config Tool**

This operation may be carried out from the PC using the *ELDES Configuration Tool* software.

### Remove scheduler from individual user

**SMS**

**SMS text message content:**

`ssss_NSCHED_ttteeellnnumm_c:OFF` or `ssss_NSCHED_user-name_c:OFF`

**Value:** `ssss` - 4-digit SMS password; `ttteeellnnumm` - up to 15 digits user phone number; `c` - scheduler number; range - [1... 8]; `user-name` - up to 16 characters user name.

**Example:** `1111_NSCHED_John_5:OFF`

**Config Tool**

This operation may be carried out from the PC using the *ELDES Configuration Tool* software.

### Set deadline for individual user

**SMS**

**SMS text message content:**

`ssss_EXPIRYTIME_ttteeellnnumm_yyyy.mm.dd_hr:mn` or `ssss_EXPIRYTIME_user-name_yyyy.mm.dd_hr:mn`

**Value:** `ssss` - 4-digit SMS password; `ttteeellnnumm` - up to 15 digits user phone number; `yyyy` - year; `mm` - month, range - [01... 12]; `dd` - day, range - [01... 31]; `hr` - hours, range - [00... 23]; `mn` - minutes, range - [00... 59]; `user-name` - up to 16 characters user name.

**Example:** `1111_EXPIRYTIME_John_2015.06.29_19:35`

### Extend deadline for individual user

**SMS**

**SMS text message content:**

`ssss_EXPIRYTIME_ttteeellnnumm_extendmins` or `ssss_EXPIRYTIME_user-name_extendmins`

**Value:** `ssss` - 4-digit SMS password; `ttteeellnnumm` - up to 15 digits user phone number; `extendmins` - time period, range - [1... 2147483648] minutes; `user-name` - up to 16 characters user name.

**Example:** `1111_EXPIRYTIME_John_2350`

**Config Tool**

This operation may be carried out from the PC using the *ELDES Configuration Tool* software.

### Remove deadline from individual user

**SMS**

**SMS text message content:**

`ssss_EXPIRYTIME_ttteeellnnumm_0` or `ssss_EXPIRYTIME_user-name_0`

**Value:** `ssss` - 4-digit SMS password; `ttteeellnnumm` - up to 15 digits user phone number; `user-name` - up to 16 characters user name.

**Example:** `1111_EXPIRYTIME_44170911XXXX1_0`

**Config Tool**

This operation may be carried out from the PC using the *ELDES Configuration Tool* software.

**View set up deadline  
for individual user**

**SMS**

**SMS text message content:**

`ssss_EXPIRYTIME_ttteeellnnumm_?` or `ssss_EXPIRYTIME_user-name_?`

**Value:** `ssss` - 4-digit SMS password; `ttteeellnnumm` - up to 15 digits user phone number; `user-name` - up to 16 characters user name.

**Example:** `1111_EXPIRYTIME_44170911XXXX1_?`

**Set ring counter for  
individual user**

**SMS**

**SMS text message content:**

`ssss_RCOUNT_ttteeellnnumm_numofcalls` or `ssss_RCOUNT_user-name_numofcalls`

**Value:** `ssss` - 4-digit SMS password; `ttteeellnnumm` - up to 15 digits administrator phone number; `user-name` - up to 16 characters user name; `numofcalls` - number of phone calls, range - [1... 4294967296].

**Example:** `1111_RCOUNT_44170911XXXX1_152`

**Config  
Tool**

This operation may be carried out from the PC using the *ELDES Configuration Tool* software.

**View set up ring  
counter value for  
individual user**

**SMS**

**SMS text message content:**

`ssss_RCOUNT_ttteeellnnumm_?` or `ssss_RCOUNT_user-name_?`

**Value:** `ssss` - 4-digit SMS password; `ttteeellnnumm` - up to 15 digits administrator phone number; `user-name` - up to 16 characters user name.

**Example:** `1111_RCOUNT_John_?`

**Config  
Tool**

This operation may be carried out from the PC using the *ELDES Configuration Tool* software.

**Remove ring counter  
from individual user**

**SMS**

**SMS text message content:**

`ssss_RCOUNT_ttteeellnnumm_0` or `ssss_RCOUNT_user-name_0`

**Value:** `ssss` - 4-digit SMS password; `ttteeellnnumm` - up to 15 digits administrator phone number; `user-name` - up to 16 characters user name.

**Example:** `1111_RCOUNT_John_0`

**Config  
Tool**

This operation may be carried out from the PC using the *ELDES Configuration Tool* software.

**ATTENTION:** If the date and time are not set, the system will NOT be able to manage user validity and access. For more details on how to set date and time, please refer to **9. DATE AND TIME**.

**NOTE:** Multiple schedulers can be assigned/removed by a single SMS text message, e. g. `1111_NSCHED_John_2:ON_6:OFF_3:OFF_5:ON`

**NOTE:** 0 value removes the set up deadline from the user.

**NOTE:** 0 value removes the set up ring counter from the user.

## 11. OUTPUTS

The system comes equipped with 2 built-in outputs. The output is intended for connection and control of the gate automation device by the following methods:

- Free of charge phone call from the user or administrator phone number (see **11.2. Output Control by Free of Charge Phone Call**).
- SMS text message from the administrator phone number (see **11.3. Output Control by SMS Text Message**).
- Automatically in accordance with the scheduled weekdays and time (see **11.6. Automatic Output Control**).

To set an output type, please refer to the following configuration method.

Set output as NO (normally-open) or NC (normally-closed)

Config Tool

This operation may be carried out from the PC using the *ELDES Configuration Tool* software.

The system allows to view the current output state by the following configuration method.

View output state

SMS

**SMS text message content:**

`ssss_STATUS`

**Value:** ssss - 4-digit SMS password.

**Example:** 1111\_STATUS

**ATTENTION:** Once the scheduler, set up for automatic output control comes into effect, the user/administrator will NOT be able to control the output by phone call and SMS text message (see **11.6. Automatic Output Control**).

### 11.1. Output Names

The outputs have names that can be customized. Typically, the name specifies a device type connected to a determined output, for example: *Gate*. The name can be used instead of output number when controlling the output by SMS text message.

By default, the output names are: C1 - *Controll1*, C2 - *Controll2*.

Set output name

SMS

**SMS text message content:**

`ssss_Co:out-name`

**Value:** ssss - 4-digit SMS password; o - output number, range [1 - output C1; 2 - output C2]; out-name - up to 16 characters output name.

**Example:** 1111\_C1:Gates

Config Tool

This operation may be carried out from the PC using the *ELDES Configuration Tool* software.

View output name

SMS

**SMS text message content:**

`ssss_STATUS`

**Value:** ssss - 4-digit SMS password.

**Example:** 1111\_STATUS

Config Tool

This operation may be carried out from the PC using the *ELDES Configuration Tool* software.

**ATTENTION:** Space, colon, semi-colon characters, parameter names and/or values, such as PSW, STATUS, ON, OFF etc. are NOT allowed in output names.

### 11.2. Output Control by Free of Charge Phone Call

To open or close the gate, dial the system's phone number from any available user or administrator phone numbers (see **10. USER PHONE NUMBER DATABASE** and **8. ADMINISTRATOR PHONE NUMBERS** for phone number management). The phone call is free charge as the system rejects it and turns ON/OFF the output (-s) for the listed time period (pulse; by default - 2 seconds) resulting in the gate opening or

closing, depending on the current gate state and selected output type NO or NC. If there is more than one listed caller dialing to the system at the same time, the system will accept the incoming call from the caller who was the first to dial while other caller (-s) will be ignored.

The system supports a confirmation phone call to user/administrator phone number. For more details, please refer to **11.4. Output Control Confirmation by Call Back**

#### Set output pulse duration

**SMS**

##### SMS text message content:

`ssss_TIMERo:p`

**Value:** *ssss* - 4-digit SMS password; *o* - output number, range [1 - output C1; 2 - output C2]; *p* - pulse duration, range - [1... 10] seconds.

**Example:** `1111_TIMER2:4`

**Config Tool**

This operation may be carried out from the PC using the *ELDES Configuration Tool* software.

**NOTE:** *ELDES Configuration Tool* software allows to set the unlimited output pulse duration value.

### 11.3. Output Control by SMS Text Message

To open or close the gate, send the SMS text message from any of 5 available administrator phone numbers (see **8. USER PHONE NUMBER DATABASE** for phone number management). The system will turn ON the output (-s) for a determined time period (pulse) resulting in the gate opening or closing, depending on the current gate state. The confirmation reply by SMS text message, containing the output name (see **11.1. Output Names**), will be sent to the administrator phone number that the output control by SMS text message was initiated from.

To instantly turn ON/OFF the output and set its state to ON/OFF when the system starts-up, please refer to the following configuration methods.

#### Turn ON output for time period

**SMS**

##### SMS text message content:

`ssss_Co:ON:hr.mn.sc` or `ssss_out-name:ON:hr.mn.sc`

**Value:** *ssss* - 4-digit SMS password; *o* - output number, range - [1... 2]; *hr* - hours, range - [00... 23]; *mn* - minutes, range - [00... 59]; *sc* - seconds, range - [00... 59]; *out-name* - up to 16 characters output name.

**Example:** `1111_C2:ON:00.00.09`

**Config Tool**

This operation may be carried out from the PC using the *ELDES Configuration Tool* software.

#### Turn OFF output for time period

**SMS**

##### SMS text message content:

`ssss_Co:OFF:hr.mn.sc` or `ssss_out-name:OFF:hr.mn.sc`

**Value:** *ssss* - 4-digit SMS password; *o* - output number, range - [1... 2]; *hr* - hours, range - [00... 23]; *mn* - minutes, range - [00... 59]; *sc* - seconds, range - [00... 59]; *out-name* - up to 16 characters output name.

**Example:** `1111_C1:OFF:00.11.49`

**Config Tool**

This operation may be carried out from the PC using the *ELDES Configuration Tool* software.

To instantly turn ON/OFF the specified output and set its state to ON/OFF when the system starts-up, please refer to the following configuration methods.

#### Turn ON output/Set output start-up state as ON

**SMS**

##### SMS text message content:

`ssss_Co:ON` or `ssss_out-name:ON`

**Value:** *ssss* - 4-digit SMS password; *o* - output number, range - [1... 2]; *out-name* - up to 16 characters output name.

**Example:** `1111_C1:ON`

**Config Tool**

This operation may be carried out from the PC using the *ELDES Configuration Tool* software.

Turn OFF output/Set output start-up state as OFF

SMS

**SMS text message content:**

`ssss_Co:OFF` or `ssss_out-name:OFF`

**Value:** *ssss* - 4-digit SMS password; *o* - output number, range - [1... 2]; *out-name* - up to 16 characters output name.

**Example:** `1111_C2:OFF`

Config Tool

This operation may be carried out from the PC using the *ELDES Configuration Tool* software.

**NOTE:** Output can be turned ON for a determined time period only when it is in OFF state.

**NOTE:** Output can be turned OFF for a determined time period only when it is in ON state.

**NOTE:** *ELDES Configuration Tool* software allows to set only the output start-up state.

**NOTE:** The administrator can control any output by SMS text message regardless of the output assigned to the administrator phone number (see **8. ADMINISTRATOR PHONE NUMBERS**).

## 11.4. Output Control Confirmation by Call Back

The system can make a phone call confirming that the output control action has been successfully carried out. Once enabled, every output control action will be followed by a 5-second (by default) ring to the user/administrator phone number that the output control by free of charge phone call was initiated from.

By default, output control confirmation by call back is disabled. To enable/disable it, please refer to the following configuration methods.

Enable output control confirmation by call back

SMS

**SMS text message content:**

`ssss_CALLBACK:ON`

**Value:** ssss - 4-digit SMS password.

**Example:** 1111\_CALLBACK:ON

Config Tool

This operation may be carried out from the PC using the *ELDES Configuration Tool* software.

Set call back duration

Config Tool

This operation may be carried out from the PC using the *ELDES Configuration Tool* software.

Disable output control confirmation by call back

SMS

**SMS text message content:**

`ssss_CALLBACK:OFF`

**Value:** ssss - 4-digit SMS password.

**Example:** 1111\_CALLBACK:OFF

Config Tool

This operation may be carried out from the PC using the *ELDES Configuration Tool* software.

## 11.5. Output Control from any Phone Number

Once an administrator phone number is listed, the system will ignore any incoming calls from a non-listed phone number. To permit/deny output control by free of charge phone call (see **11. OUTPUTS**) from a non-listed phone number, please refer to the following configuration methods.

Enable output control from any phone number

SMS

**SMS text message content:**

`ssss_ALLNUM:ON`

**Value:** ssss - 4-digit SMS password.

**Example:** 1111\_ALLNUM:ON

Config Tool

This operation may be carried out from the PC using the *ELDES Configuration Tool* software.

Disable output control from any phone number

SMS

**SMS text message content:**

`ssss_ALLNUM:OFF`

**Value:** ssss - 4-digit SMS password.

**Example:** 1111\_ALLNUM:OFF

Config Tool

This operation may be carried out from the PC using the *ELDES Configuration Tool* software.

**NOTE:** The system will accept SMS text messages only from a listed administrator phone number even if output control from any phone number is enabled.

**NOTE:** Once the output control from any phone number is enabled, a non-listed phone number user will be able to control output C1 only.

## 11.6. Automatic Output Control

The system comes equipped with automatic output control in accordance with the assigned scheduler (-s). When one or more schedulers are assigned, the output will automatically turn ON/OFF on the specified weekdays and time set up in the scheduler. The system allows to assign up to 8 different schedulers. For more details on how to set up the schedulers, please refer to **12. SCHEDULERS**.

### Assign scheduler

SMS

**SMS text message content:**

`ssss_OSHEDo_c:ON`

**Value:** ssss - 4-digit SMS password; o - output number, range [1 - output C1; 2 - output C2]; c - scheduler number; range - [1... 8].

**Example:** `1111_OSCHED2_1:ON`

Config  
Tool

This operation may be carried out from the PC using the *ELDES Configuration Tool* software.

### Remove scheduler

SMS

**SMS text message content:**

`ssss_OSHEDo_c:OFF`

**Value:** ssss - 4-digit SMS password; o - output number, range [1 - output C1; 2 - output C2]; c - scheduler number; range - [1... 8].

**Example:** `1111_OSCHED1_5:OFF`

Config  
Tool

This operation may be carried out from the PC using the *ELDES Configuration Tool* software.

**ATTENTION:** Once the scheduler, set up for automatic output control, comes into effect, the user/administrator will NOT be able to control the output by phone call and SMS text message.

## 12. SCHEDULERS

The system comes equipped with 8 schedulers that allow to set up the day (-s) of the week and time parameters. The schedulers are used to set up user validity and access restriction (see **10.1. User Validity and Access Restriction**) as well as automatic output control (see **11.6. Automatic Output Control**). Each scheduler includes the following parameters:

- **Every Day** - Determines whether the scheduler will be valid everyday regardless of the current day of the week.
- **At Specified Day (-s)** - Determines day (-s) in the week when the scheduler is to be valid.
- **Start Time** - Determines the point in time when the scheduler is to take effect.
- **End Time** - Determines the point in time when the scheduler is to cease to take effect.

### Select At Specified Day (-s)

SMS

**SMS text message content:**

`ssss_SCHEDc_AL:OFF`

**Value:** ssss - 4-digit SMS password; c - scheduler number; range - [1... 8].

**Example:** 1111\_SCHED4\_AL:OFF

Config Tool

This operation may be carried out from the PC using the *ELDES Configuration Tool* software.

### Enable day (-s) of the week

SMS

**SMS text message content:**

`ssss_SCHEDc_wd:ON`

**Value:** ssss - 4-digit SMS password; c - scheduler number; range - [1... 8]; wd - weekday, range - [MO - Monday; TU - Tuesday; WE - Wednesday; TH - Thursday; FR - Friday; SA - Saturday; SU - Sunday].

**Example:** 1111\_SCHED6\_FR:ON

Config Tool

This operation may be carried out from the PC using the *ELDES Configuration Tool* software.

### Disable day (-s) of the week

SMS

**SMS text message content:**

`ssss_SCHEDc_wd:OFF`

**Value:** ssss - 4-digit SMS password; c - scheduler number; range - [1... 8]; wd - weekday, range - [MO - Monday; TU - Tuesday; WE - Wednesday; TH - Thursday; FR - Friday; SA - Saturday; SU - Sunday].

**Example:** 1111\_SCHED4\_SU:OFF

Config Tool

This operation may be carried out from the PC using the *ELDES Configuration Tool* software.

### Set start time

SMS

**SMS text message content:**

`ssss_SCHEDc_st:hr:mn`

**Value:** ssss - 4-digit SMS password; c - scheduler number; hr - hours, range - [00... 23]; mn - minutes, range - [00... 59].

**Example:** 1111\_SCHED2\_ST:20:25

Config Tool

This operation may be carried out from the PC using the *ELDES Configuration Tool* software.

### Set end time

SMS

**SMS text message content:**

`ssss_SCHEDc_en:hr:mn`

**Value:** ssss - 4-digit SMS password; c - scheduler number; hr - hours, range - [00... 23]; mn - minutes, range - [00... 59].

**Example:** 1111\_SCHED8\_EN:09:12

Select Every Day

**Config  
Tool**

This operation may be carried out from the PC using the *ELDES Configuration Tool* software.

**SMS**

**SMS text message content:**

`ssss_SCHEDc_AL:ON`

**Value:** ssss - 4-digit SMS password; c - scheduler number, range - [1... 8]

**Example:** `1111_SCHED1_AL:ON`

**Config  
Tool**

This operation may be carried out from the PC using the *ELDES Configuration Tool* software.

**NOTE:** Multiple scheduler parameters can be configured by a single SMS text message, e. g. `1111_SCHED2_MO:ON_FR:OFF_EN:20:18_TH:OFF_ST:15:25_TU:ON_AL:OFF`

### 13. EVENT LOG

This feature allows to chronologically register up to 1000 timestamped records regarding the following system events:

- Output control including the user/administrator phone number and user name.
- User validity expiry by deadline.
- User validity expiry by ring counter.
- Automatic output control beginning.
- Automatic output control ending.

To export the event log to .log file or clear it, please refer to the following configuration methods.

Export event log

Config Tool

This operation may be carried out from the PC using the *ELDES Configuration Tool* software.

By default, when the event log reaches the 1000 record limit, the system will send the notification by SMS text message to the administrator phone number. To clear the event log and/or disable/enable the notification regarding the full event log, please refer to the following configuration methods.

Clear event log

SMS

**SMS text message content:**

`ssss_DELETELOG`

**Value:** ssss - 4-digit SMS password.

**Example:** 1111\_DELETELOG

Config Tool

This operation may be carried out from the PC using the *ELDES Configuration Tool* software.

Disable Log Full notification

Config Tool

This operation may be carried out from the PC using the *ELDES Configuration Tool* software.

Enable Log Full notification

Config Tool

This operation may be carried out from the PC using the *ELDES Configuration Tool* software.

By default, the event log is set as of LIFO (last in, first out) type that allows the system to automatically replace the oldest records with the the latest ones.. To disable/enable it, please refer to the following configuration methods.

Disable LIFO type log

Config Tool

This operation may be carried out from the PC using the *ELDES Configuration Tool* software.

Enable LIFO type log

Config Tool

This operation may be carried out from the PC using the *ELDES Configuration Tool* software.

## 14. INPUTS

The system comes equipped with 3 inputs designed for fault indication output or detection device connection, such as door contacts. Once a fault indication output and/or a detection device is triggered, the system will send a notification to the administrator phone number. Typically, the inputs are used to receive notifications regarding jammed gate or gate state. For more details, please refer to **14.1. Input Names and Alarm Notifications**.

Each input's sensitivity level can be customized by a delay time (by default - 600 milliseconds). If an input is left triggered until the delay time expires, the input is considered violated.

### Set input delay

SMS

#### SMS text message content:

`ssss_Tn:in-delay`

**Value:** ssss - 4-digit SMS password; n - input number, range - [1... 3]; in-delay - input delay, range - [100... 42000000] milliseconds.

**Example:** 1111\_T3:10500

Config  
Tool

This operation may be carried out from the PC using the *ELDES Configuration Tool* software.

The system allows to view the current input state by the following configuration method.

### View input state

SMS

#### SMS text message content:

`ssss_INFO`

**Value:** ssss - 4-digit SMS password;

**Example:** 1111\_INFO

### 14.1. Input Names and Alarm Notifications

Each input has a name that can be customized. Typically, the name specifies a device type connected to a certain input terminal, for example: *GateOpen*. The input names are used in notifications that are sent by SMS text message to the administrator regarding the input alarm event. By default, the input names are: Z1 - zone1, Z2 - zone2, Z3 - zone3.

### Set input name

SMS

#### SMS text message content:

`ssss_Zn:input-name`

**Value:** ssss - 4-digit SMS password; n - input number, range - [1... 3]; input-name - up to 8 characters input name.

**Example:** 1111\_Z2:GateOpen

Config  
Tool

This operation may be carried out from the PC using the *ELDES Configuration Tool* software.

### View input names

SMS

#### SMS text message content:

`ssss_STATUS`

**Value:** ssss - 4-digit SMS password.

**Example:** 1111\_STATUS

Config  
Tool

This operation may be carried out from the PC using the *ELDES Configuration Tool* software.

By default, the system sends SMS text message to the first available administrator in case of input alarm. If the system did not receive the SMS delivery report during 20 seconds, it will attempt to send the SMS text message to the next listed administrator phone number. To ignore the SMS delivery report and allow/disallow the system to send the SMS text message to every listed administrator phone number, please refer to the following configuration methods.

Enable notification to all listed administrator phone numbers in case of input alarm

SMS

**SMS text message content:**

`ssss_SMSALL:ON`

**Value:** ssss - 4-digit SMS password.

**Example:** 1111\_SMSALL:ON

Config Tool

This operation may be carried out from the PC using the *ELDES Configuration Tool* software.

Disable notification to all listed administrator phone numbers in case of input alarm

SMS

**SMS text message content:**

`ssss_SMSALL:OFF`

**Value:** ssss - 4-digit SMS password.

**Example:** 1111\_SMSALL:OFF

Config Tool

This operation may be carried out from the PC using the *ELDES Configuration Tool* software.

**ATTENTION:** Space characters, parameter values, such as ON, OFF etc. are NOT allowed in the input names. Space characters, parameter values, such as ON, OFF etc. are NOT allowed in the input names.

For more details on how to disable the input alarm notifications, please refer to **14.2. Disabling and Enabling Inputs**.

For more details on the algorithm of how the system sends the notifications, please refer to **16. SYSTEM NOTIFICATIONS**.

## 14.2. Disabling and Enabling Inputs

By default, all inputs are enabled. Once disabled, input alarm event will no longer be followed by an SMS text message. To disable/enable an individual input, please refer to the following configuration methods.

Disable input

SMS

**SMS text message content:**

`ssss_Zn:OFF`

**Value:** ssss - 4-digit SMS password; *n* - input number, range - [1... 3]; *input-name* - up to 8 characters input name.

**Example:** 1111\_Z3:OFF

Config Tool

This operation may be carried out from the PC using the *ELDES Configuration Tool* software.

Enable input

SMS

**SMS text message content:**

`ssss_Zn:ON`

**Value:** ssss - 4-digit SMS password; *n* - input number, range - [1... 3]; *input-name* - up to 8 characters input name.

**Example:** 1111\_Z2:ON

Config Tool

This operation may be carried out from the PC using the *ELDES Configuration Tool* software.

View input status

SMS

**SMS text message content:**

`ssss_STATUS`

**Value:** ssss - 4-digit SMS password.

**Example:** 1111\_STATUS

Config Tool

This operation may be carried out from the PC using the *ELDES Configuration Tool* software.

## 15. SYSTEM INFORMATION. INFO SMS

The system supports an informational SMS text message identified as the Info SMS, which can be delivered upon request. Once requested, the system will reply with Info SMS that provides the following:

- System date and time.
- GSM signal strength.
- Number of occupied and empty slots in the user database.
- State of inputs (OK/alarm).

### Request system information

SMS

#### SMS text message content:

`ssss_INFO`

**Value:** ssss - 4-digit SMS password.

**Example:** 1111\_INFO

Config Tool

This operation may be carried out from the PC using the *ELDES Configuration Tool* software.

For more details on the algorithm of how the system sends the notifications, please refer to **16. SYSTEM NOTIFICATIONS**.

### 15.1. Periodic Info SMS

The system may send the Info SMS to the administrator phone number periodically. By default, the period is daily at 11:00 (frequency - 1 day; time - 11). The minimum period is every 1 hour (frequency - 0 days; time - 1). Typically, this feature is used to verify the operation status of the system.

To enable periodic Info SMS by setting the frequency and time or disable it, please refer to the following configuration methods.

### Set periodic Info SMS frequency and time

SMS

#### SMS text message content:

`ssss_INFO:fff:it`

**Value:** ssss - 4-digit SMS password; *fff* - frequency, range - [00... 99] days; *it* - time, range - [01... 23].

**Example:** 1111\_INFO:3.15

Config Tool

This operation may be carried out from the PC using the *ELDES Configuration Tool* software.

### Disable periodic Info SMS

SMS

#### SMS text message content:

`ssss_INFO:00:00`

**Value:** ssss - 4-digit SMS password.

**Example:** 1111\_INFO:00.00

Config Tool

This operation may be carried out from the PC using the *ELDES Configuration Tool* software.

## 16. SYSTEM NOTIFICATIONS

In case of a certain event, the system attempts to send an SMS text message to the first listed administrator phone number only. If the administrator phone number is unavailable and the system fails to receive the SMS delivery report within 20 seconds, it will attempt to send the SMS text message to the next listed administrator phone number. The administrator phone number may be unavailable due to the following reasons:

- Mobile phone was switched off.
- Was out of GSM signal coverage.

The system will continue sending the SMS text message to the next listed administrator phone numbers in the priority order until one is available. The system sends the SMS text message only once and will not return to the first administrator phone number if the last one was unavailable.

### 16.1. SMS Text Message Delivery Restrictions

By default, the system is restricted to send out up to 25 SMS text messages daily and up to 400 SMS text messages monthly. To change the limits or disable SMS text message delivery restrictions, please refer to the following configuration method.

Manage SMS text message delivery limits

Config Tool

This operation may be carried out from the PC using the *ELDES Configuration Tool* software.

When the daily or monthly SMS text message delivery limit is exceeded, the system will notify the administrator by SMS text message. The limit counter will automatically reset once the date and time synchronization period takes effect (by default - every 30 days). Alternatively, you can reset the limits by referring to the following configuration method.

Reset SMS text message delivery limit counter

SMS

**SMS text message content:**

`ssss_REMOVEBAN`

**Value:** ssss - 4-digit SMS password.

**Example:** `1111_REMOVEBAN`

**NOTE:** 0 value disables daily/monthly SMS text message delivery restrictions.

See also **9.1. Automatic Date and Time Synchronization.**

### 16.2. SMSC (Short Message Service Center) Phone Number

An SMS center (SMSC) is a GSM network element, which routes SMS text messages to the destination recipient and stores the SMS text message if the recipient is unavailable. Typically, the phone number of the SMS center is already stored in the SIM card provided by the GSM operator. If the administrator fails to receive replies from the system, the SMS center phone number, provided by the GSM operator, must be set manually.

Set SMSC phone number

SMS

**SMS text message content:**

`ssss_SMS_+ttteeeInnuumm`

**Value:** ssss - 4-digit SMS password; `ttteeeInnuumm` - up to 15 digits SMSC phone number.

**Example:** `1111_SMS_+44170311XXXX1`

**ATTENTION:** Before setting the SMSC phone number, please check the credit balance of the system's SIM card. The system will fail to reply if the credit balance is insufficient.

## 17. GPRS NETWORK SETTINGS

The GPRS network settings are used for device communication with the remote configuration server or ELDES Cloud Services server via GPRS connection. To set the GPRS network settings, please refer to the following configuration methods.

### Set APN

SMS

**SMS text message content:**

`ssss_SETGPRS:APN:acc-point-name`

**Value:** ssss - 4-digit SMS password; *acc-point-name* - up to 31 character APN (Access Point Name) provided by the GSM operator.

**Example:** `1111_SETGPRS:APN:internet`

Config  
Tool

This operation may be carried out from the PC using the *ELDES Configuration Tool* software.

### Set user name

SMS

**SMS text message content:**

`ssss_SETGPRS:USER:usr-name`

**Value:** ssss - 4-digit SMS password; *usr-name* - up to 31 character user name provided by the GSM operator.

**Example:** `1111_USER:mobileusr`

Config  
Tool

This operation may be carried out from the PC using the *ELDES Configuration Tool* software.

### Set password

SMS

**SMS text message content:**

`ssss_SETGPRS:PSW:password`

**Value:** ssss - 4-digit SMS password; *password* - up to 31 character password provided by the GSM operator.

**Example:** `1111_SETGPRS:PSW:mobilepsw`

Config  
Tool

This operation may be carried out from the PC using the *ELDES Configuration Tool* software.

### View GPRS network settings

SMS

**SMS text message content:**

`ssss_SETGPRS?`

**Value:** ssss - 4-digit SMS password.

**Example:** `1111_SETGPRS?`

Config  
Tool

This operation may be carried out from the PC using the *ELDES Configuration Tool* software.

**NOTE:** Multiple parameters can be set by single SMS text message, e.g. `1111_SETGPRS:APN:internet;USER:mobileusr;PSW:mobilepsw`

## 18. INCOMING PHONE NUMBER VERIFICATION SETTINGS

**ATTENTION:** Due to security reasons it is NOT recommended to configure the parameters described below.

The system comes equipped with a phone number length verification feature allowing to restrict access for the phone numbers of a certain length. By default, the system supports the administrator and user phone numbers consisting of at least 4 digits (minimum phone number length), while the last 7 digits of the caller's phone number are used for comparison with the listed phone number in order to identify whether the phone number is listed. By default, the system will ignore all phone numbers consisting of less than 4 digits even if the phone number is listed as the administrator phone number or the user phone number. However, the system will accept all incoming phone calls containing a phone number matching the last 7 digits of the listed phone number.

Manage incoming  
phone number  
verification settings

Config  
Tool

This operation may be carried out from the PC using the *ELDES Configuration Tool* software.

## 19. REMOTE SYSTEM RESTART

In some critical situations, a system restart may be required. To remotely carry out system restart, please refer to the following configuration method.

Restart the system

SMS

**SMS text message content:**

`ssss_RESTART`

**Value:** ssss - 4-digit SMS password.

**Example:** `1111_RESTART`

## 20. TECHNICAL SUPPORT

### 20.1. Troubleshooting

Indication	Possible reason
Indicators SIM STAT and NETW are OFF	<ul style="list-style-type: none"><li>· No mains power</li><li>· Wrong wiring</li><li>· Blown fuse</li><li>· Disconnected antenna</li><li>· Micro-controller could not start due to electrical mains noise or static discharge</li></ul>
Indicator SIM STAT is ON	<ul style="list-style-type: none"><li>· Missing SIM card</li><li>· PIN code is enabled</li><li>· SIM card is inactive</li></ul>
Indicator SIM STAT is flashing	<ul style="list-style-type: none"><li>· GSM connection fault</li></ul>
Unable to receive any SMS text messages to the administrator phone number or control the output	<ul style="list-style-type: none"><li>· Insufficient SIM card credit balance</li><li>· Caller's phone number is set up as withheld (hidden)</li><li>· No GSM network signal</li><li>· Wrong administrator/user phone number</li><li>· Administrator/user phone number is not set</li><li>· SIM card was replaced before disconnecting mains power</li><li>· Incorrect SMS center phone number</li></ul>
Unable to connect to the device remotely via GPRS connection	<ul style="list-style-type: none"><li>· GPRS settings (APN, user name, password) not set.</li><li>· Insufficient SIM card credit balance</li><li>· Mobile internet service (GPRS) not activated on the SIM card.</li></ul>
Received SMS text message "Wrong syntax"	<ul style="list-style-type: none"><li>· Incorrect SMS text message structure</li><li>· Unnecessary space character might have been typed in SMS text message</li></ul>

For product warranty repair service, please contact your local retail store where this product was purchased.

If your problem could not be fixed by the self-guide above, please contact your local distributor. More up to date information about your device and other products can be found at the manufacturer's website [www.eldes.lt](http://www.eldes.lt)

### 20.2. Restoring Default Parameters

1. Power down the device.
2. Short-circuit (connect) the DEF pins.
3. Power up the device for 7 seconds.
4. Power down the device.
5. Remove the short-circuit from DEF pins.
6. Parameters restored to default.

### 20.3. Updating the Firmware via USB Cable

1. Power down the device.
2. Short-circuit (connect) the DEF pins.
3. Connect the device via USB cable to the PC.
4. Power up the device.
5. The new window must pop-up where you will find the .bin file. Otherwise open *My Computer* and look for *Boot Disk* drive.
6. Delete the .bin file found in the drive.
7. Copy the new firmware .bin file to the very same window.
8. Power down the device.
9. Unplug the USB cable.
10. Remove the short-circuit from DEF pins.
11. Power up the device.
12. Firmware updated.

**NOTE:** It is strongly recommended to restore default parameters after the firmware update.

# Downee

**Customer Service** (03) 9364 8288

See [downee.com.au](http://downee.com.au) for your state office

**Tech Support** 1800 241 733 [techsupport@downee.com.au](mailto:techsupport@downee.com.au)

**[downee.com.au](http://downee.com.au)**